

**DIXI 72420 PCD**  
Ø8 x 16 x 32 x Ø 10 x 58 Z=2

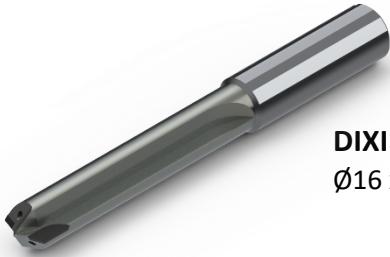

**DIXI 15020 PCD**  
Monobloc drill with  
HSK63 attachment



**DIXI 11180 PCD**  
Ø16 x 9 x 85 x Ø 6 x 120 Z=6

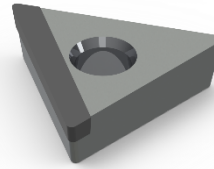

**DIXI 26420**  
TCMW 110204

### Application example: Carbon brake machining

#### Purpose:

To improve tool life and maintain the repeatability of the hole diameters to be machined.

#### Tool :

DIXI 11180 Ø 3.8 x 25 x Ø 6 x 58 Z=2 SP

#### Material :

Carbon

#### Machine :

5-axis machining centre

#### Cooling :

none

#### Cutting conditions:

N=6500 rpm

Vf=435mm/min

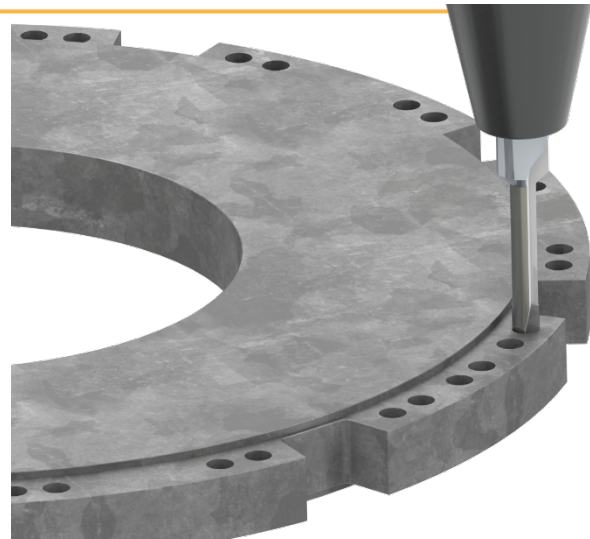

#### Result :

The diameters are constant and the process is reliable.

