

Faswerkzeuge

zur Vorwärts- und Rückwärtsbearbeitung

- Geeignet für alle Materialien
- Von Ø 0.20 bis 5.70 mm
- Senkung 45°

SENKFRÄSER

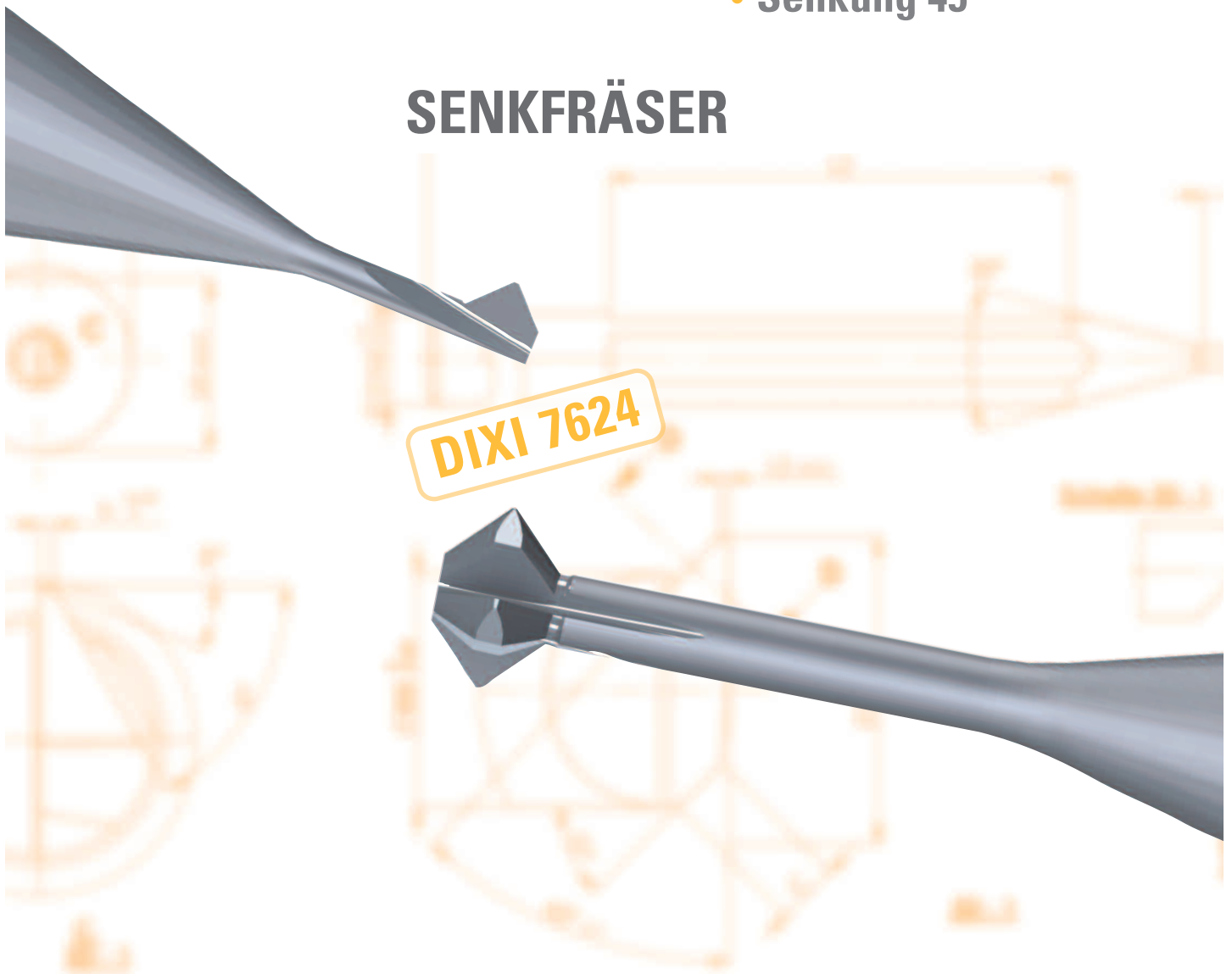

DIXI 7624

SENKFRÄSER

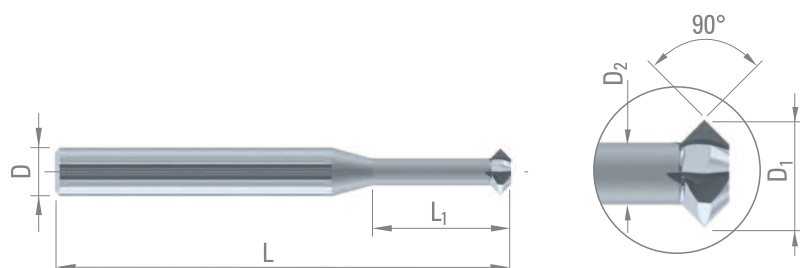
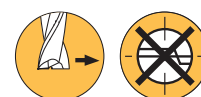

Stahl + Pb	Niedrig leg. Stahl	Hochleg. Stahl	Aust. Rostfreier Stahl	Gusseisen
Sonderlegierung Ni / Co	Titan, Titanlegierung	Kupfer Leg. Silber Gold	Kupfer Leg. schwer zerspanbar	Alu
Kunststoff				

D ₁	L ₁	D ₂	ch	D _{h6}	L	Z	VHM
0.20	0.4	0.12	0.04	3	38	1	997990
0.25	0.5	0.15	0.05	3	38	1	997991
0.30	0.6	0.18	0.06	3	38	1	997992
0.40	0.8	0.24	0.08	3	38	1	997993
0.50	1.0	0.30	0.10	3	38	1	997994
0.60	1.2	0.36	0.12	3	38	3	997995
0.70	1.4	0.42	0.14	3	38	3	997996
0.80	1.6	0.48	0.16	3	38	3	997997
0.90	1.8	0.54	0.18	3	38	3	997998
1.00	2.0	0.60	0.20	3	38	3	997999
1.20	2.4	0.70	0.25	3	38	4	998000
1.30	2.6	0.70	0.30	3	38	4	998001
1.80	5.4	1.00	0.40	3	38	4	998002
2.80	8.4	1.60	0.60	3	38	4	998003
3.70	11.1	2.10	0.80	6	57	4	998004
5.70	17.1	3.30	1.20	6	57	4	998005

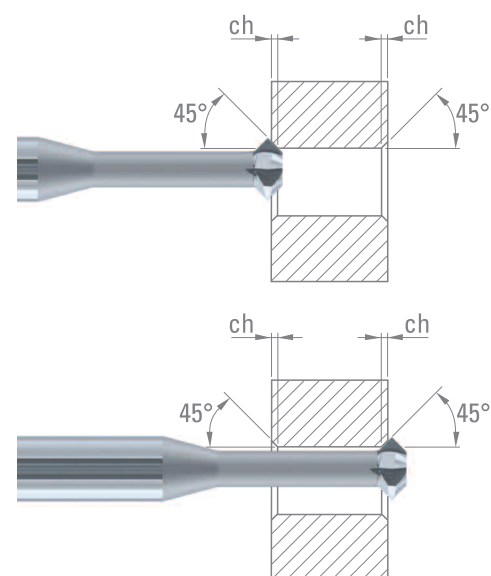

DIXI POLYTOOL S.A.
 Av. du Technicum 37
 CH-2400 Le Locle

Tel. +41 (0)32 933 54 44
 Fax +41 (0)32 931 89 16

dixipoly@dixi.ch

www.dixipolytool.com