

$$n \text{ [tr/min]} = \frac{Vc \text{ [m/min]} \times 1000}{\pi \times D_1 \text{ [mm]}}$$

$$Vf \text{ [mm/min]} = n \text{ [tr/min]} \times fz \text{ [mm]} \times Z$$

Zu bearbeitender Werkstoff		Ø 0.30 - 0.80		Ø 0.80 - 1.60		Ø 1.60 - 5.00	
		VHM	C-TOP	VHM	C-TOP	VHM	C-TOP
		Vc [m/min]	Vc [m/min]	Vc [m/min]	Vc [m/min]	Vc [m/min]	Vc [m/min]
<b>P</b>	Niedrig leg. / unleg. Stahl	< 600 N/mm <sup>2</sup>	35 - 120		110 - 200		200 - 260
<b>P</b>	Niedrig leg. / unleg. Stahl	600 – 1500 N/mm <sup>2</sup>	25 - 100		80 - 170		160 - 200
<b>P</b>	Bleilegiertes Automatenstahl		40 - 130		120 - 200		220 - 280
<b>P</b>	Hochlegierter Stahl	700 – 1500 N/mm <sup>2</sup>	20 - 80		70 - 120		100 - 190
<b>M</b>	Rostfreier Stahl	400 – 700 N/mm <sup>2</sup>	30 - 85		85 - 190		190 - 260
<b>M</b>	DUPLEX rostfreier Stahl	> 800 N/mm <sup>2</sup>	25 - 65		65 - 145		155 - 220
<b>K</b>	Grauguss / Sphäroguss perlitisch	< 250 HB	35 - 45	35 - 95	55 - 135	120 - 200	80 - 165
<b>K</b>	Leg. Grauguss / Sphäroguss perlitisch	> 250 HB	30 - 40	35 - 80	50 - 110	90 - 150	70 - 140
<b>K</b>	Sphäroguss ferritisch / Temperguss		25 - 35	35 - 75	45 - 100	85 - 125	65 - 120
<b>S</b>	Sonderlegierungen / Warmfester rostfreier Stahl	Inconel Nimonic Hastelloy	20 - 35		60 - 100		90 - 130
<b>S</b>	Titan, Titanlegierung		20 - 40	35 - 45	40 - 90	80 - 150	60 - 130
<b>N</b>	Kupfer-Legierung / gut zerspanbar (Messing – Bronze)		40 - 60	45 - 120	60 - 110	120 - 200	90 - 165
<b>N</b>	Kupfer-Legierung / schwer zerspanbar / Aluminium-Bronze	(CuAlFe)	30 - 50	45 - 90	45 - 105	90 - 180	70 - 160
<b>N</b>	Gold, Silber	(Ampco)	35 - 55	45 - 90	60 - 105	90 - 180	85 - 180

Ø 0.30 - 0.50		Ø 0.50 - 0.80		Ø 0.80 - 1.60		Ø 1.60 - 3.00		Ø 3.00 - 5.00	
fz	ae ap	fz	ae ap	fz	ae ap	fz	ae ap	fz	ae ap
0.005 - 0.007	< 0.20 x Ø < 1.00 x Ø	0.007 - 0.013	< 0.25 x Ø < 1.00 x Ø	0.013 - 0.029	< 0.30 x Ø < 1.00 x Ø	0.029 - 0.040	< 0.35 x Ø < 1.00 x Ø	0.040 - 0.058	< 0.35 x Ø < 1.00 x Ø
0.004 - 0.006	< 0.20 x Ø < 1.00 x Ø	0.006 - 0.011	< 0.30 x Ø < 1.00 x Ø	0.011 - 0.024	< 0.30 x Ø < 1.00 x Ø	0.024 - 0.038	< 0.35 x Ø < 1.00 x Ø	0.038 - 0.054	< 0.35 x Ø < 1.00 x Ø
0.006 - 0.008	< 0.20 x Ø < 1.00 x Ø	0.008 - 0.014	< 0.25 x Ø < 1.00 x Ø	0.014 - 0.030	< 0.30 x Ø < 1.00 x Ø	0.030 - 0.042	< 0.35 x Ø < 1.00 x Ø	0.042 - 0.060	< 0.35 x Ø < 1.00 x Ø
0.004 - 0.006	< 0.15 x Ø < 1.00 x Ø	0.006 - 0.011	< 0.20 x Ø < 1.00 x Ø	0.011 - 0.024	< 0.30 x Ø < 1.00 x Ø	0.024 - 0.038	< 0.30 x Ø < 1.00 x Ø	0.038 - 0.054	< 0.30 x Ø < 1.00 x Ø
0.006 - 0.008	< 0.15 x Ø < 1.00 x Ø	0.008 - 0.014	< 0.25 x Ø < 1.00 x Ø	0.014 - 0.030	< 0.30 x Ø < 1.00 x Ø	0.030 - 0.042	< 0.30 x Ø < 1.00 x Ø	0.042 - 0.060	< 0.30 x Ø < 1.00 x Ø
0.003 - 0.005	< 0.10 x Ø < 1.00 x Ø	0.005 - 0.009	< 0.25 x Ø < 1.00 x Ø	0.009 - 0.025	< 0.30 x Ø < 1.00 x Ø	0.025 - 0.036	< 0.30 x Ø < 1.00 x Ø	0.036 - 0.048	< 0.30 x Ø < 1.00 x Ø
0.006 - 0.008	< 0.20 x Ø < 1.00 x Ø	0.008 - 0.014	< 0.30 x Ø < 1.00 x Ø	0.014 - 0.030	< 0.30 x Ø < 1.00 x Ø	0.030 - 0.042	< 0.35 x Ø < 1.00 x Ø	0.042 - 0.060	< 0.35 x Ø < 1.00 x Ø
0.004 - 0.006	< 0.20 x Ø < 1.00 x Ø	0.006 - 0.011	< 0.25 x Ø < 1.00 x Ø	0.011 - 0.024	< 0.30 x Ø < 1.00 x Ø	0.024 - 0.046	< 0.35 x Ø < 1.00 x Ø	0.046 - 0.060	< 0.35 x Ø < 1.00 x Ø
0.004 - 0.006	< 0.10 x Ø < 1.00 x Ø	0.006 - 0.011	< 0.25 x Ø < 1.00 x Ø	0.011 - 0.024	< 0.30 x Ø < 1.00 x Ø	0.024 - 0.046	< 0.35 x Ø < 1.00 x Ø	0.046 - 0.060	< 0.35 x Ø < 1.00 x Ø
0.002 - 0.004	< 0.10 x Ø < 1.00 x Ø	0.004 - 0.008	< 0.15 x Ø < 1.00 x Ø	0.008 - 0.011	< 0.20 x Ø < 1.00 x Ø	0.011 - 0.021	< 0.25 x Ø < 1.00 x Ø	0.021 - 0.035	< 0.25 x Ø < 1.00 x Ø
0.004 - 0.006	< 0.20 x Ø < 1.00 x Ø	0.006 - 0.013	< 0.20 x Ø < 1.00 x Ø	0.013 - 0.020	< 0.25 x Ø < 1.00 x Ø	0.020 - 0.032	< 0.30 x Ø < 1.00 x Ø	0.032 - 0.042	< 0.30 x Ø < 1.00 x Ø
0.008 - 0.010	< 0.20 x Ø < 1.00 x Ø	0.010 - 0.017	< 0.30 x Ø < 1.00 x Ø	0.017 - 0.034	< 0.30 x Ø < 1.00 x Ø	0.034 - 0.052	< 0.35 x Ø < 1.00 x Ø	0.052 - 0.066	< 0.40 x Ø < 1.00 x Ø
0.005 - 0.007	< 0.25 x Ø < 1.00 x Ø	0.007 - 0.013	< 0.35 x Ø < 1.00 x Ø	0.013 - 0.029	< 0.35 x Ø < 1.00 x Ø	0.029 - 0.048	< 0.40 x Ø < 1.00 x Ø	0.048 - 0.062	< 0.40 x Ø < 1.00 x Ø
0.005 - 0.007	< 0.25 x Ø < 1.00 x Ø	0.007 - 0.013	< 0.35 x Ø < 1.00 x Ø	0.013 - 0.029	< 0.35 x Ø < 1.00 x Ø	0.029 - 0.048	< 0.40 x Ø < 1.00 x Ø	0.048 - 0.062	< 0.40 x Ø < 1.00 x Ø

SCHNITTBEDINGUNGEN - NUTBEARBEITUNG

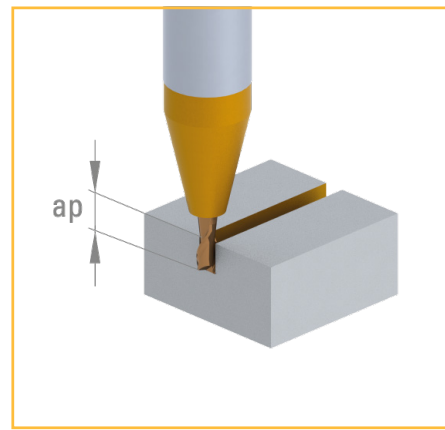

$$n \text{ [tr/min]} = \frac{Vc \text{ [m/min]} \times 1000}{\pi \times D_1 \text{ [mm]}}$$

$$Vf \text{ [mm/min]} = n \text{ [tr/min]} \times fz \text{ [mm]} \times Z$$

Zu bearbeitender Werkstoff		Ø 0.30 - 0.80		Ø 0.80 - 1.60		Ø 1.60 - 5.00	
		VHM	C-TOP	VHM	C-TOP	VHM	C-TOP
		Vc [m/min]	Vc [m/min]	Vc [m/min]	Vc [m/min]	Vc [m/min]	Vc [m/min]
<b>P</b>	Niedrig leg. / unleg. Stahl	< 600 N/mm <sup>2</sup>	25 - 45		40 - 130		120 - 280
<b>P</b>	Niedrig leg. / unleg. Stahl	600 – 1500 N/mm <sup>2</sup>	25 - 45		40 - 120		90 - 230
<b>P</b>	Bleilegiertes Automatenstahl		30 - 50		45 - 130		110 - 280
<b>P</b>	Hochlegierter Stahl	700 – 1500 N/mm <sup>2</sup>	20 - 45		40 - 110		90 - 190
<b>M</b>	Rostfreier Stahl	400 – 700 N/mm <sup>2</sup>	25 - 50		45 - 120		100 - 230
<b>M</b>	DUPLEX rostfreier Stahl	> 800 N/mm <sup>2</sup>	15 - 35		30 - 90		75 - 180
<b>K</b>	Grauguss / Sphäroguss perlitisch	< 250 HB	25 - 45	30 - 90	45 - 125	80 - 180	70 - 165
<b>K</b>	Leg. Grauguss / Sphäroguss perlitisch	> 250 HB	20 - 40	30 - 80	40 - 100	70 - 150	60 - 140
<b>K</b>	Sphäroguss ferritisch / Temperguss		20 - 35	30 - 70	35 - 90	60 - 125	55 - 120
<b>S</b>	Sonderlegierungen / Warmfester rostfreier Stahl	Inconel Nimonic Hastelloy	20 - 30		30 - 80		60 - 140
<b>S</b>	Titan, Titanlegierung		20 - 40	30 - 45	30 - 80	40 - 130	50 - 130
<b>N</b>	Kupfer-Legierung / gut zerspanbar (Messing – Bronze)		40 - 50	45 - 120	50 - 100	120 - 200	80 - 165
<b>N</b>	Kupfer-Legierung / schwer zerspanbar / Aluminium-Bronze	(CuAlFe)	30 - 40	45 - 90	40 - 95	90 - 180	60 - 140
<b>N</b>	Gold, Silber	(Ampco)	35 - 45	45 - 120	50 - 100	120 - 200	75 - 170

Ø 0.30 - 0.50		Ø 0.50 - 0.80		Ø 0.80 - 1.60		Ø 1.60 - 3.00		Ø 3.00 - 5.00	
fz	ap	fz	ap	fz	ap	fz	ap	fz	ap
0.004 - 0.006	< 0.50 x Ø	0.006 - 0.011	< 0.80 x Ø	0.011 - 0.022	< 1.00 x Ø	0.022 - 0.043	< 1.00 x Ø	0.043 - 0.050	< 1.00 x Ø
0.003 - 0.005	< 0.50 x Ø	0.005 - 0.009	< 0.80 x Ø	0.009 - 0.020	< 1.00 x Ø	0.020 - 0.041	< 1.00 x Ø	0.041 - 0.048	< 1.00 x Ø
0.005 - 0.007	< 0.50 x Ø	0.007 - 0.010	< 0.80 x Ø	0.010 - 0.028	< 1.00 x Ø	0.028 - 0.044	< 1.00 x Ø	0.044 - 0.049	< 1.00 x Ø
0.003 - 0.005	< 0.50 x Ø	0.005 - 0.009	< 0.80 x Ø	0.009 - 0.020	< 1.00 x Ø	0.020 - 0.040	< 1.00 x Ø	0.040 - 0.048	< 1.00 x Ø
0.003 - 0.005	< 0.50 x Ø	0.005 - 0.009	< 0.80 x Ø	0.009 - 0.020	< 1.00 x Ø	0.020 - 0.043	< 1.00 x Ø	0.043 - 0.048	< 1.00 x Ø
0.002 - 0.003	< 0.50 x Ø	0.003 - 0.007	< 0.80 x Ø	0.007 - 0.015	< 1.00 x Ø	0.015 - 0.032	< 1.00 x Ø	0.032 - 0.045	< 1.00 x Ø
0.004 - 0.006	< 0.50 x Ø	0.006 - 0.011	< 0.80 x Ø	0.011 - 0.025	< 1.00 x Ø	0.025 - 0.043	< 1.00 x Ø	0.043 - 0.050	< 1.00 x Ø
0.003 - 0.006	< 0.50 x Ø	0.005 - 0.010	< 0.80 x Ø	0.010 - 0.020	< 1.00 x Ø	0.020 - 0.040	< 1.00 x Ø	0.040 - 0.047	< 1.00 x Ø
0.003 - 0.006	< 0.50 x Ø	0.006 - 0.011	< 0.80 x Ø	0.010 - 0.019	< 1.00 x Ø	0.019 - 0.038	< 1.00 x Ø	0.038 - 0.042	< 1.00 x Ø
0.001 - 0.003	< 0.50 x Ø	0.003 - 0.007	< 0.80 x Ø	0.007 - 0.010	< 1.00 x Ø	0.010 - 0.018	< 1.00 x Ø	0.018 - 0.025	< 1.00 x Ø
0.003 - 0.004	< 0.50 x Ø	0.004 - 0.008	< 0.80 x Ø	0.008 - 0.015	< 1.00 x Ø	0.015 - 0.032	< 1.00 x Ø	0.032 - 0.040	< 1.00 x Ø
0.005 - 0.009	< 0.50 x Ø	0.009 - 0.015	< 0.80 x Ø	0.015 - 0.028	< 1.00 x Ø	0.028 - 0.048	< 1.00 x Ø	0.048 - 0.060	< 1.00 x Ø
0.005 - 0.007	< 0.50 x Ø	0.007 - 0.010	< 0.80 x Ø	0.010 - 0.025	< 1.00 x Ø	0.025 - 0.043	< 1.00 x Ø	0.043 - 0.052	< 1.00 x Ø
0.005 - 0.008	< 0.50 x Ø	0.008 - 0.012	< 0.80 x Ø	0.012 - 0.027	< 1.00 x Ø	0.027 - 0.046	< 1.00 x Ø	0.046 - 0.050	< 1.00 x Ø