

Nouvelles fraises
DIXI 7340-3.5D
DIXI 7340-5D

De stock
du $\varnothing 0.2\text{mm}$
à $\varnothing 1\text{mm}$

Un allié incontournable
pour des empreintes
hexalobulaires
de très grande précision.

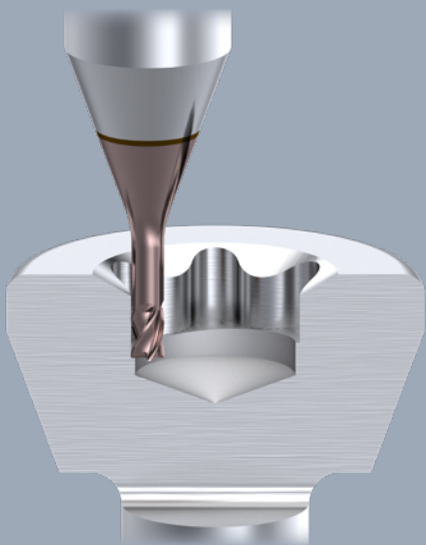

PERÇAGE D'UNE EMPREINTE HEXALOBULAIRE

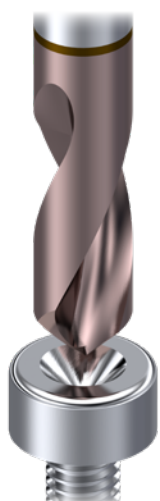

Opération 1
Centrage et chanfreinage
Outil standard de stock
DIXI 1105-90°

+

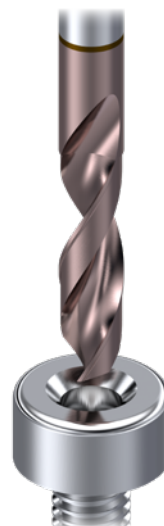

Opération 2
Perçage
Outil standard de stock
DIXI 1137

Alternative

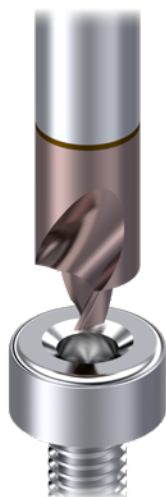

Opération 1 et 2
Perçage et chanfreinage
Outil spécial sur demande
DIXI 1501

FRAISAGE D'UNE EMPREINTE HEXALOBULAIRE

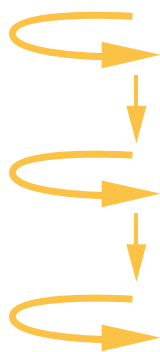

Opération 3
Contournage
DIXI 7340-xD



Opération 3
Interpolation hélicoïdale
DIXI 7340-xD

AVANTAGES TECHNIQUES

Le fraisage par interpolation hélicoïdale offre de nombreux avantages:

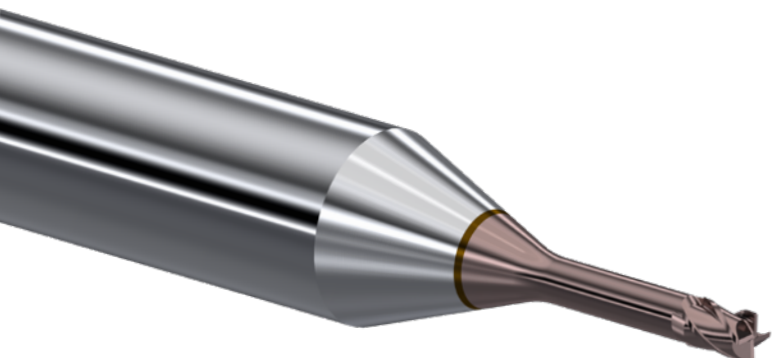

- 1** Meilleure précision du profil hexalobe.
- 2** Aucune vibration lors de l'usinage des rayons intérieurs des lobes.
- 3** Réduction du temps de cycle.

- 4** Excellente qualité de l'état de surface obtenue grâce à la constance et la répartition des efforts lors de l'usinage en interpolation.

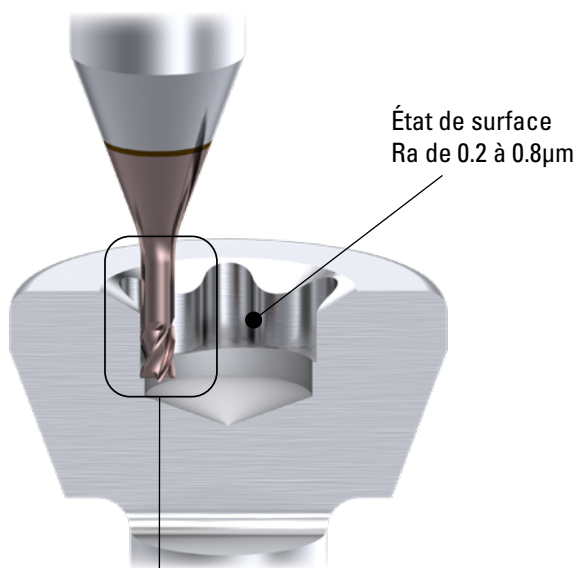

- 5** Perpendicularité du profil parfaite grâce à une flexion minimale de la fraise.

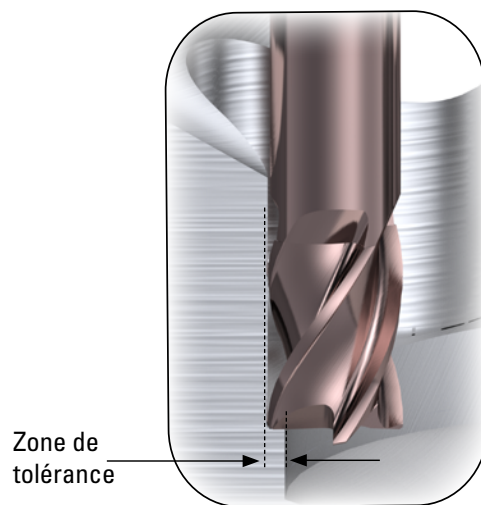

DIXI 7340-xD

Z = 3-4

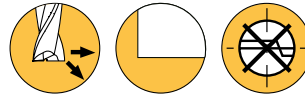

**FRAISES 2 TAILLES À CORPS RENFORCÉ
POUR EMPREINTES HEXALOBULAIRES**

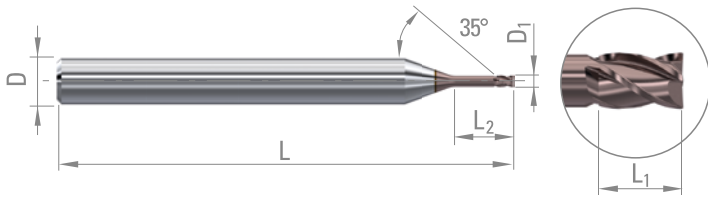

- Fraises 2 tailles, corps renforcé et dégagées $3.5 \times D_1$ et $5 \times D_1$, développées pour l'usinage d'empreintes hexalobulaires en titane, aciers inoxydables et CoCr.
- Le revêtement C-TOP extra lisse améliore la durée de vie, même à température élevée, dans les matériaux à usinabilité difficile.

Ébauche ●●●○○○ Finition ●●●●●○○ bien ○ excellent ○

ISO	P													M				K							
Description matières	Acier non allié					Acier faiblement allié					Acier fort. allié et acier à outils			Acier inox. fer. marten.		Acier inox. austénitique (DUPLEX / PH)				Fonte grise		Fonte nodulaire		Fonte malléable	
VDI 3323	1	2	3	4	5	6	7	8	9	10	11	12	13	14.1	14.2	14.3	14.4	15	16	17	18	19	20		
Recommandations	○	○	○	○	○	○	○	○	○	○	○	○	○	○	○	○	○	○	○	○	○	○	○	○	

ISO	N													S					H				
Description matières	Alliage alu corroyé		Alliage alu coulé			Alliage Cu+Pb		Alliage Cu difficile		Or, Argent	Graphite	Plastique	Bois	Alliage réfractaire			Titane, alliage de titane		Acier trempé		Fonte dure		
VDI 3323	21	22	23	24	25	26	27	28	-	-	29	30	31	32	33-35	36	37	38	39	40	41		
Recommandations	○	○	○	○	○	○	○	○	○				○	○	○	○	○						

TORX	$D_{10/0.1}$	L_1	D_2	D_{h5}	L	Z	L_2	DIXI	C-TOP
T4	0.20	0.3	0.19	4	38	3	0.70 1.00	7340-3.5D 7340-5D	444218 444219
T5/T6	0.25	0.4	0.23	4	38	3	0.90 1.25	7340-3.5D 7340-5D	446482 446483
T6 / T7	0.30	0.5	0.28	4	38	3	1.10 1.50	7340-3.5D 7340-5D	444220 444221
T8 / T10	0.40	0.6	0.38	4	38	4	1.40 2.00	7340-3.5D 7340-5D	444222 444223
T10 / T15	0.50	0.8	0.48	4	38	4	1.80 2.50	7340-3.5D 7340-5D	444224 444225
T15/T20	0.60	0.9	0.58	4	38	4	2.10 3.00	7340-3.5D 7340-5D	444226 444227
T20/T25	0.70	1.0	0.68	4	38	4	2.50 3.50	7340-3.5D 7340-5D	444228 444229
T25	0.80	1.2	0.75	4	38	4	2.80 4.00	7340-3.5D 7340-5D	444230 444231
T30	0.90	1.4	0.85	4	38	4	3.20 4.50	7340-3.5D 7340-5D	444232 444233
T30 / T40	1.00	1.5	0.94	4	38	4	3.50 5.00	7340-3.5D 7340-5D	444234 444235

EXEMPLE D'USINAGE D'UNE EMPREINTE HEXALOBULAIRE LOBE INTERNE R=0.30 mm

Outil : Fraise DIXI 7340-3.5D Ø0.5 réf 444224

$n = 50'000$ tr/min

$V_f = 350$ mm/min

Usinage par interpolation hélicoïdale.

Pas de 0.05 mm par hélice.

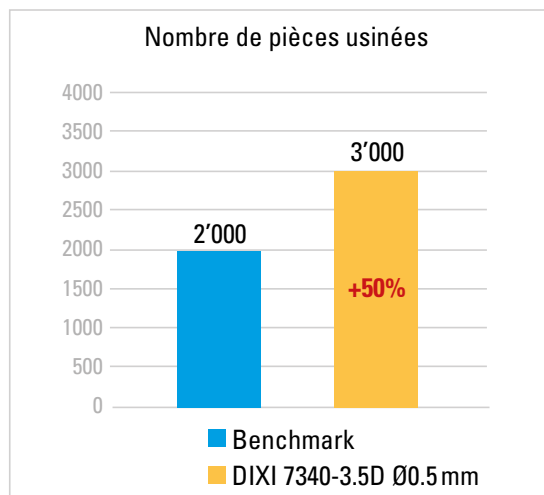

DÉCOUVREZ LA VIDÉO

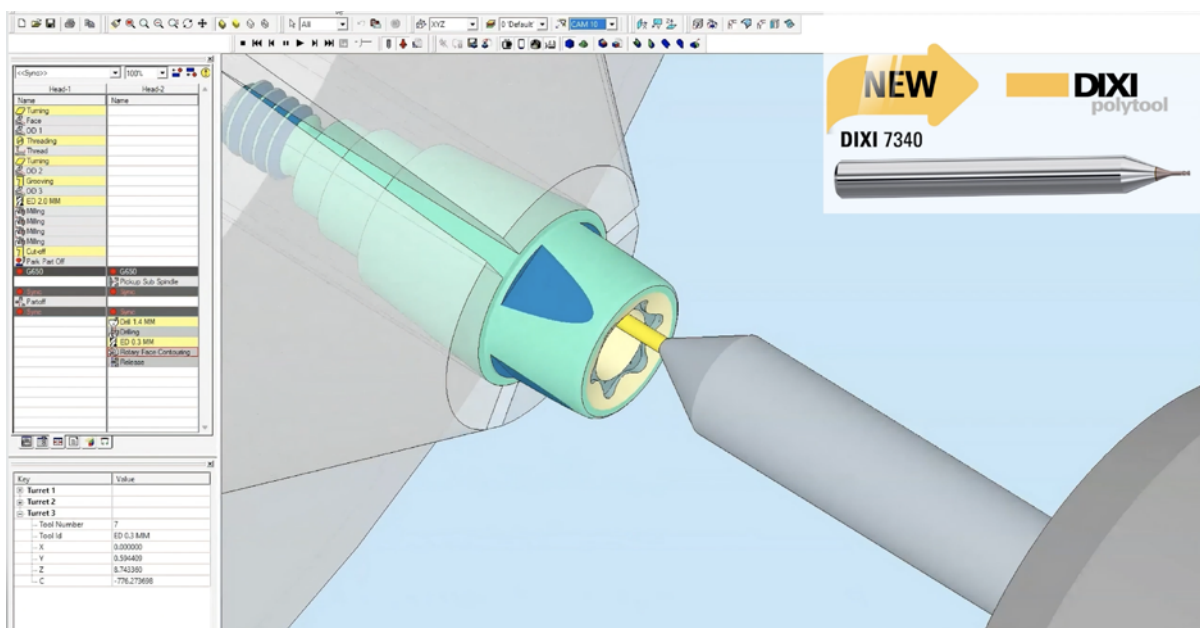

CONDITIONS DE COUPE

INTERPOLATION HÉLICOÏDALE



	VDI 3323	T4 Ø D ₁ = 0.20				T5 Ø D ₁ = 0.25				T6/T7 Ø D ₁ = 0.30				
		P		Vc (m/min)	fz (mm)	P		Vc (m/min)	fz (mm)	P		Vc (m/min)	fz (mm)	
		3.5xD ₁	5xD ₁			3.5xD ₁	5xD ₁			3.5xD ₁	5xD ₁			
M	Acier inoxydable austénitique <700 N/mm ²	14.1-14.2	0.2xD ₁	0.15xD ₁	20	0.0015	0.2xD ₁	0.15xD ₁	25	0.0015	0.3xD ₁	0.2xD ₁	30	0.0025
	Acier inoxydable sans Ni / DUPLEX > 700 N/mm ²	14.3-14.4	0.2xD ₁	0.15xD ₁	20	0.0015	0.2xD ₁	0.15xD ₁	25	0.0015	0.3xD ₁	0.2xD ₁	30	0.0025
S	Alliage réfractaire, base Fe, Ni, Co	31 - 35	0.2xD ₁	0.15xD ₁	20	0.0010	0.2xD ₁	0.15xD ₁	25	0.0010	0.3xD ₁	0.2xD ₁	30	0.0020
	Titane, alliage de titane	36 - 37	0.2xD ₁	0.15xD ₁	20	0.0015	0.2xD ₁	0.15xD ₁	25	0.0015	0.3xD ₁	0.2xD ₁	30	0.0025

CONTOURNAGE



	VDI 3323	T4 Ø D ₁ = 0.20				T5 Ø D ₁ = 0.25				T6/T7 Ø D ₁ = 0.30				
		ae (mm)	ap (mm)	Vc (m/min)	fz (mm)	ae (mm)	ap (mm)	Vc (m/min)	fz (mm)	ae (mm)	ap (mm)	Vc (m/min)	fz (mm)	
		M	Acier inoxydable austénitique <700 N/mm ²			14.1-14.2	0.1xD ₁			0.5xD ₁	20			0.0018
Acier inoxydable sans Ni / DUPLEX > 700 N/mm ²	14.3-14.4		0.1xD ₁	0.5xD ₁	20	0.0018	0.1xD ₁	0.5xD ₁	25	0.0018	0.1xD ₁	0.5xD ₁	30	0.0018
S	Alliage réfractaire, base Fe, Ni, Co	31 - 35	0.1xD ₁	0.5xD ₁	20	0.0012	0.1xD ₁	0.5xD ₁	25	0.0012	0.1xD ₁	0.5xD ₁	30	0.0012
	Titane, alliage de titane	36 - 37	0.1xD ₁	0.5xD ₁	20	0.0018	0.1xD ₁	0.5xD ₁	25	0.0018	0.1xD ₁	0.5xD ₁	30	0.0018

POINTAGE / CHANFREINAGE

Tout matériau



	Pointage-Chanfreinage	
	90°	120°
T4	DIXI 1105-Ø2.00	DIXI 1107-Ø2.00
T5	DIXI 1105-Ø2.00	DIXI 1107-Ø2.00
T6	DIXI 1105-Ø3.00	DIXI 1107-Ø3.00
T7	DIXI 1105-Ø3.00	DIXI 1107-Ø3.00
T8	DIXI 1105-Ø3.00	DIXI 1107-Ø3.00
T10	DIXI 1105-Ø4.00	DIXI 1107-Ø4.00
T15	DIXI 1105-Ø4.00	DIXI 1107-Ø4.00
T20	DIXI 1105-Ø5.00	DIXI 1107-Ø5.00
T25	DIXI 1105-Ø5.00	DIXI 1107-Ø5.00
T30	DIXI 1105-Ø6.00	DIXI 1107-Ø6.00
T40	DIXI 1105-Ø6.00	DIXI 1107-Ø6.00

T8/T10 Ø D1 = 0.40				T10/T15 Ø D1 = 0.50				T15/T20 Ø D1 = 0.60				T20 Ø D1 = 0.70				T25/T40 Ø D1 = 0.80/1.00			
P		Vc (m/min)	fz (mm)	P		Vc (m/min)	fz (mm)	P		Vc (m/min)	fz (mm)	P		Vc (m/min)	fz (mm)	P		Vc (m/min)	fz (mm)
3.5xD ₁	5xD ₁			3.5xD ₁	5xD ₁			3.5xD ₁	5xD ₁			3.5xD ₁	5xD ₁			3.5xD ₁	5xD ₁		
0.35xD ₁	0.25xD ₁	30	0.0025	0.4xD ₁	0.3xD ₁	40	0.0025	0.4xD ₁	0.3xD ₁	40	0.0030	0.4xD ₁	0.3xD ₁	40	0.0030	0.50xD ₁	0.40xD ₁	50	0.0040
0.35xD ₁	0.25xD ₁	30	0.0025	0.4xD ₁	0.3xD ₁	40	0.0025	0.4xD ₁	0.3xD ₁	40	0.0030	0.4xD ₁	0.3xD ₁	40	0.0030	0.50xD ₁	0.40xD ₁	50	0.0040
0.35xD ₁	0.25xD ₁	30	0.0020	0.4xD ₁	0.3xD ₁	40	0.0020	0.4xD ₁	0.3xD ₁	40	0.0025	0.4xD ₁	0.3xD ₁	40	0.0025	0.50xD ₁	0.40xD ₁	50	0.0030
0.35xD ₁	0.25xD ₁	30	0.0025	0.4xD ₁	0.3xD ₁	40	0.0025	0.4xD ₁	0.3xD ₁	40	0.0030	0.4xD ₁	0.3xD ₁	40	0.0030	0.50xD ₁	0.40xD ₁	50	0.0040

T8/T10 Ø D1 = 0.40				T10/T15 Ø D1 = 0.50				T15/T20 Ø D1 = 0.60				T20 Ø D1 = 0.70				T25/T40 Ø D1 = 0.80/1.00			
ae (mm)	ap (mm)	Vc (m/min)	fz (mm)	ae (mm)	ap (mm)	Vc (m/min)	fz (mm)	ae (mm)	ap (mm)	Vc (m/min)	fz (mm)	ae (mm)	ap (mm)	Vc (m/min)	fz (mm)	ae (mm)	ap (mm)	Vc (m/min)	fz (mm)
0.2xD ₁	0.5xD ₁			30	0.0030			0.2xD ₁	0.5xD ₁			40	0.0030			0.2xD ₁	0.5xD ₁		
0.2xD ₁	0.5xD ₁	30	0.0030	0.2xD ₁	0.5xD ₁	40	0.0030	0.2xD ₁	0.5xD ₁	40	0.0036	0.3xD ₁	0.5xD ₁	40	0.0036	0.3xD ₁	0.5xD ₁	50	0.0048
0.2xD ₁	0.5xD ₁	30	0.0024	0.2xD ₁	0.5xD ₁	40	0.0024	0.2xD ₁	0.5xD ₁	40	0.0030	0.3xD ₁	0.5xD ₁	40	0.0030	0.3xD ₁	0.5xD ₁	50	0.0036
0.2xD ₁	0.5xD ₁	30	0.0030	0.2xD ₁	0.5xD ₁	40	0.0030	0.2xD ₁	0.5xD ₁	40	0.0036	0.3xD ₁	0.5xD ₁	40	0.0036	0.3xD ₁	0.5xD ₁	50	0.0048

PERÇAGE

Titanes



Perçage trou central
Ø D₁ selon ISO 10664

T4	DIXI 1137 Ø0.90
T5	DIXI 1137 Ø1.00
T6	DIXI 1137 Ø1.20
T7	DIXI 1137 Ø1.40
T8	DIXI 1137 Ø1.60
T10	DIXI 1137 Ø1.90
T15	DIXI 1137 Ø2.30
T20	DIXI 1137 Ø2.70
T25	DIXI 1137 Ø3.10
T30	DIXI 1137 Ø3.80
T40	DIXI 1137 Ø4.70

Chrome Cobalt et Aciers inoxydables

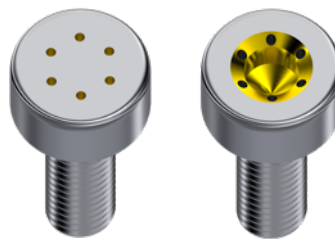

Perçage trou central
Ø D₁ selon ISO 10664

T4	DIXI 1137 Ø0.90
T5	DIXI 1137 Ø0.10
T6	DIXI 1137 Ø1.20
T7	DIXI 1137 Ø1.40
T8	DIXI 1137 Ø1.60
T10	DIXI 1137 Ø1.90
T15	DIXI 1137 Ø2.30
T20	DIXI 1137 Ø2.70
T25	DIXI 1137 Ø3.10
T30	DIXI 1137 Ø3.80
T40	DIXI 1137 Ø4.70

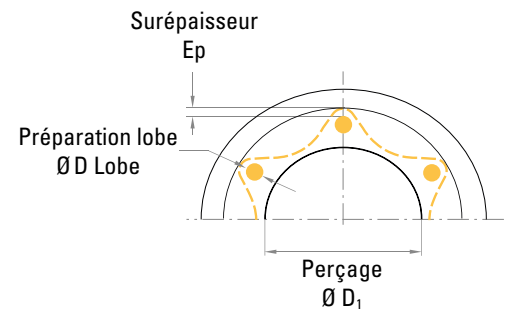

Perçage trou lobes

surépaisseur = 10% x D lobes

T4	DIXI 1137 Ø0.25
T5	DIXI 1137 Ø0.25
T6	DIXI 1137 Ø0.30
T7	DIXI 1137 Ø0.35
T8	DIXI 1137 Ø0.40
T10	DIXI 1137 Ø0.50
T15	DIXI 1137 Ø0.60
T20	DIXI 1137 Ø0.70
T25	DIXI 1137 Ø0.80
T30	DIXI 1137 Ø1.00
T40	DIXI 1137 Ø1.20

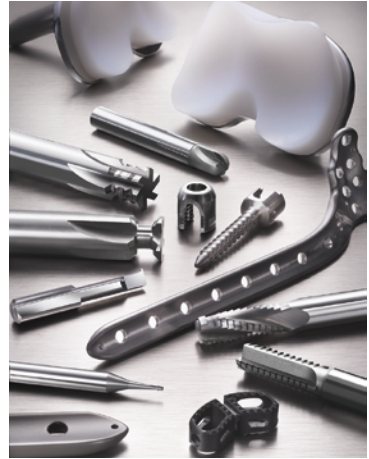

DIXI
polytool



DIXI POLYTOOL S.A.
Av. du Technicum 37
CH - 2400 Le Locle
T. +41 (0)32 933 54 44
dixipoly@dixi.ch
www.dixipolytool.com