

ZAHNFORMFRÄSER

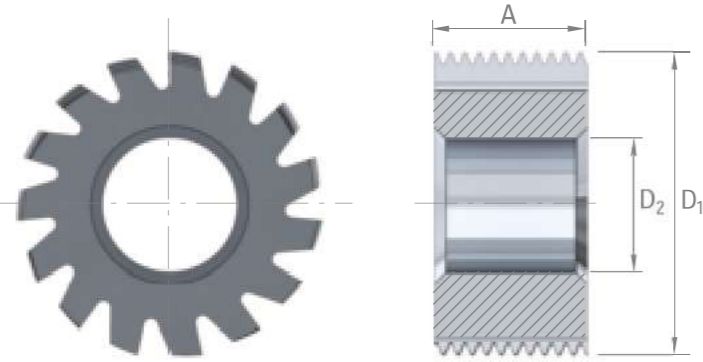

Stahl +Pb	Niedrig leg. Stahl	Hochleg. Stahl	Aust. Rostfreier Stahl	Titan, Titanlegierung
Kupfer Leg. Silber Gold	Kupfer Leg. schwer zerspanbar	Alu		

Modul (m) = 0.03 - 0.5

D ₁	A	D _{2H3}	Z	VHM
6	4	3.5	12	<input type="checkbox"/>
8	5	3.5	12	<input type="checkbox"/>
10	4	3.5	12	<input type="checkbox"/>
10	5	3.5	12	<input type="checkbox"/>
12	6	3.5	12	<input type="checkbox"/>
16	8	8.0	12	<input type="checkbox"/>
18	8	8.0	12	<input type="checkbox"/>
24	8	8.0	12	<input type="checkbox"/>
24	10	8.0	12	<input type="checkbox"/>



ZAHNFORMFRÄSER

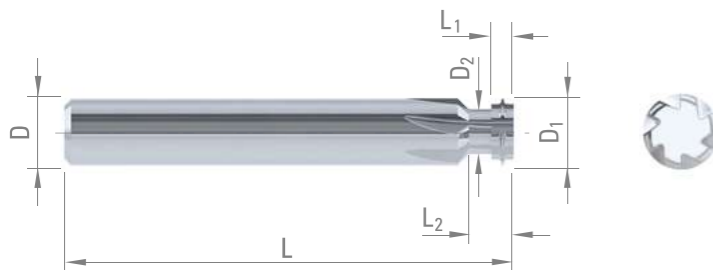

D ₁ -0.05/-0.10	L ₁	D ₂	L ₂	D _{h5}	L	Z	VHM
5.0	2.0	4.0	4.15	5	42	6	<input type="checkbox"/>
6.0	2.0	4.0	4.15	6	42	6	<input type="checkbox"/>



ABWÄLZFRÄSER

- Ab Modul 0.04 bis zu 0.5
- Abwälzfräsen
- Profile nach Normen der Uhrindustrie (NIHS, EVJ, NHS, usw...)

DIXI 1675

DIXI 1685

DIXI 1674

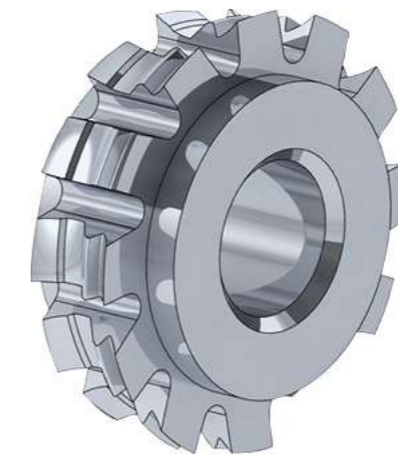

DIXI POLYTOOL S.A.
 Av. du Technicum 37
 CH-2400 Le Locle
 T +41 (0)32 933 54 44
 F +41 (0)32 931 89 16
 dixipoly@dixi.ch

Mikrowerkzeuge sind DIXI Werkzeuge

www.dixipolytool.com

ABWÄLZFRÄSER
EVOLVENTE UND ZYKLOIDE

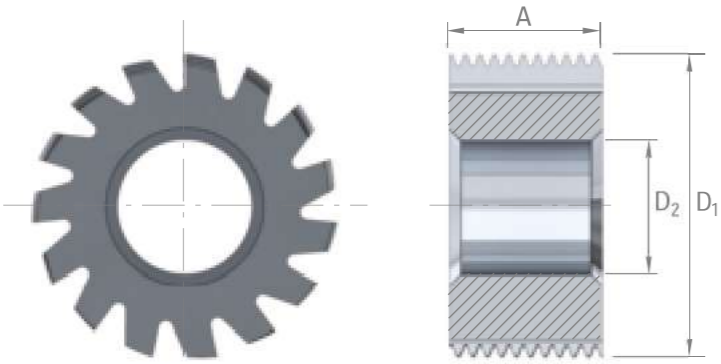

Stahl +Pb	Niedrig leg. Stahl	Hochleg. Stahl	Aust. Rostfreier Stahl	Titan, Titan-legierung
Kupfer Leg. Silber Gold	Kupfer Leg. schwer zerspanbar	Alu		

Modul (m) = 0.04 - 0.5

D ₁	A	D _{2H3}	Z	VHM
6	4	3.5	12	<input type="checkbox"/>
	5	3.5	12	<input type="checkbox"/>
8	4	3.5	15	<input type="checkbox"/>
	5	3.5	12	<input type="checkbox"/>
10	4	3.5	15	<input type="checkbox"/>
	5	3.5	12	<input type="checkbox"/>
	6	3.5	15	<input type="checkbox"/>
12	6	4.5	12	<input type="checkbox"/>
	6	4.5	15	<input type="checkbox"/>
	8	4.5	15	<input type="checkbox"/>
	6	8.0	12	<input type="checkbox"/>
16	6	8.0	15	<input type="checkbox"/>
	8	8.0	12	<input type="checkbox"/>
	8	8.0	15	<input type="checkbox"/>
18	8	8.0	12	<input type="checkbox"/>
	8	8.0	15	<input type="checkbox"/>
	8	8.0	12	<input type="checkbox"/>
24	8	8.0	15	<input type="checkbox"/>
	10	8.0	12	<input type="checkbox"/>
	10	8.0	15	<input type="checkbox"/>

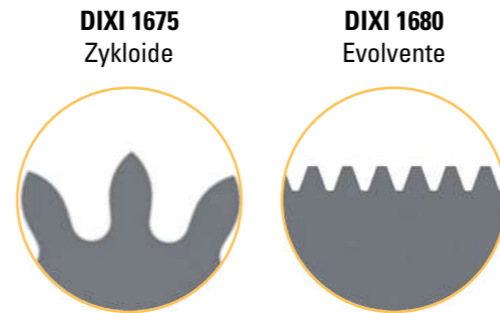

Nachsleifbar
logarithmisches Profil



Beschichtung auf Anfrage

EINSTELL-ABWÄLZFRÄSER

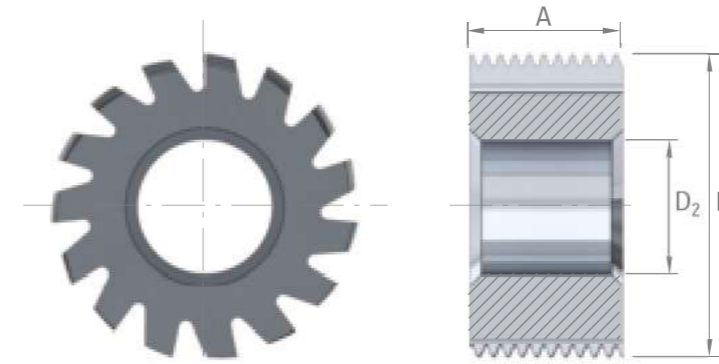

Stahl +Pb	Niedrig leg. Stahl	Hochleg. Stahl	Aust. Rostfreier Stahl	Titan, Titan-legierung
Kupfer Leg. Silber Gold	Kupfer Leg. schwer zerspanbar	Alu		

D ₁	A	D _{2H3}	Z	VHM
6	4	3.5	12	<input type="checkbox"/>
6	5	3.5	12	<input type="checkbox"/>
8	5	3.5	12	<input type="checkbox"/>
10	5	3.5	12	<input type="checkbox"/>
12	6	4.5	12	<input type="checkbox"/>
16	6	8.0	12	<input type="checkbox"/>
16	8	8.0	12	<input type="checkbox"/>
18	8	8.0	12	<input type="checkbox"/>
24	8	8.0	12	<input type="checkbox"/>
24	10	8.0	12	<input type="checkbox"/>

